

TECHNICAL DATA SHEET

F - 100 - 04 FRAME HINGE & STRIKE SPECIFICATIONS

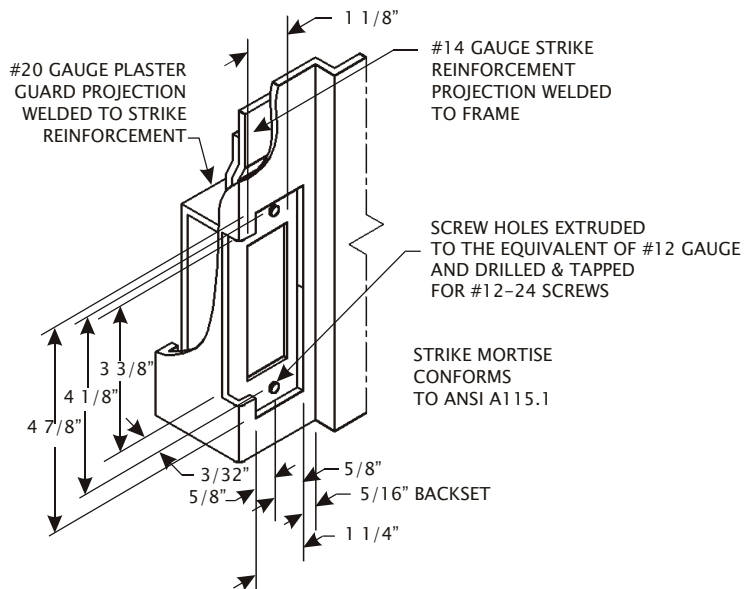
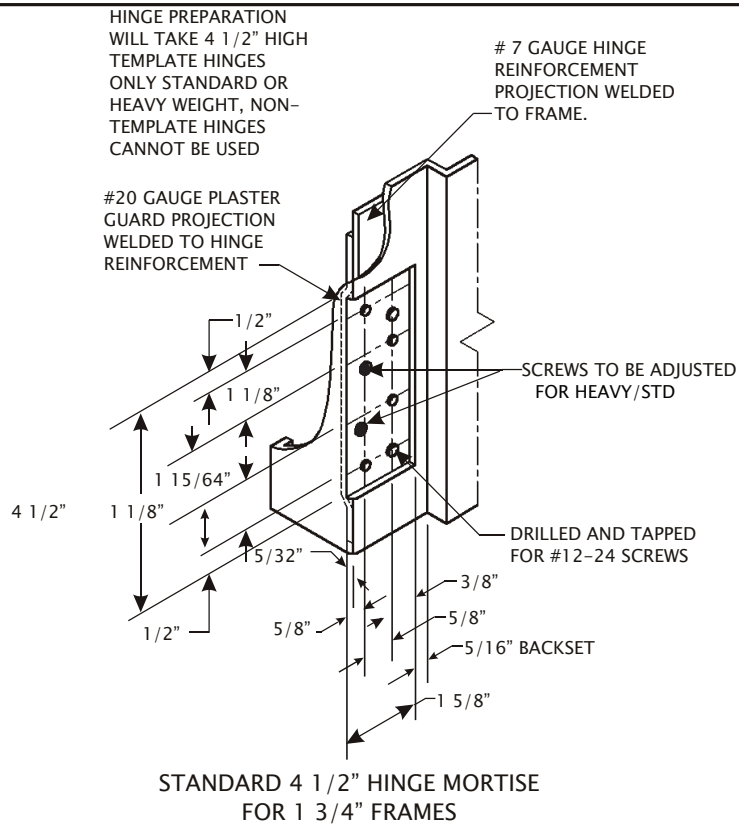

ANSI A 115

Issue Date: July 2009

REVISED : 07/01/2009

